



A-Level Physics

Analogue and Digital Signals

Mark Scheme

Time available: 48 minutes

Marks available: 35 marks

www.accesstuition.com

Mark schemes

1.

- (a) Photoconductive mode
 Accept 'reverse bias'

1

- (b) Dark currents will become a source of noise – need to keep S:N as high as possible
 OWTTE

OR

Need to have a large difference in signal when detector is in light and dark ✓

Must include idea of 'noise'

OR

Must include concept of large signal change to represent digital signal

1

- (c) At 850 nm, $R_\lambda = 0.50 \text{ A/W}$ ✓
 Reading from graph
 Allow 0.49 A/W to 0.51 A/W

Using $R_\lambda = \frac{I_p}{P}$ $I_p = R_\lambda \times P$ $0.50 \times 4 \times 10^{-6} = 2 \mu\text{A}$ ✓ ecf

$V_{\text{out}} = I_p \times R = 2 \mu\text{A} \times 560 \text{ k}\Omega = +1.12 \text{ V}$ ✓

Accept voltage in range of 1.10 V to 1.14 V

Accept value without + sign

3

- (d)

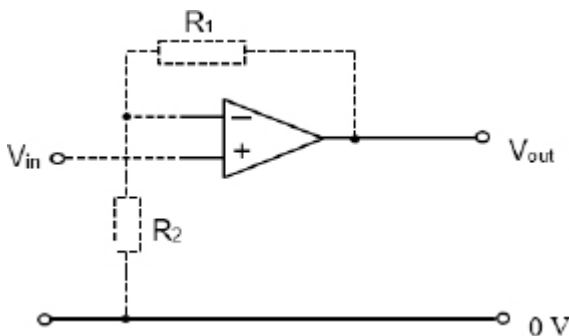

Correct configuration of R_1 and R_2 ✓

$R_1 : R_2$ ratio 3 : 1 in suggested range ✓

Label the input point which must have a direct connection to the non-inverting input ✓

One mark only

An inverting op amp configuration with a voltage gain -4 .

3

[8]

2.

- (a) Audio range (bandwidth) is 20 kHz ✓

The sampling frequency should be at least **twice** the maximum frequency / bandwidth ✓

*Reference to Nyquist theorem without reference to numerical data –
1 mark only*

2

- (b) 6.5536×10^4

*Allow other correct numbers
eg 65536*

1

- (c) For one channel:

$$44.1 \times 10^3 \times 16 \times 3.5 \times 60 = 148.175 \text{ megabits. } \checkmark$$

For Stereo:

$$(2 \times 148.175) \div 8 = 37.04 \text{ megabytes } \checkmark$$

(Accept 37 megabytes)

Two marks for 37 megabytes with no working shown.

2

- (d) Lower quality music over telephone line due to: telephone call has lower bandwidth than original audio file ✓

loss of high and low frequencies from music ✓

One mark for general comment relating to ratio of bandwidths of the two systems where CD bandwidth has been taken to be in region of 15 kHz – 20 kHz

2

[7]

3.

The mark scheme gives some guidance as to what statements are expected to be seen in a 1 or 2 mark (L1), 3 or 4 mark (L2) and 5 or 6 mark (L3) answer.

Level	Criteria	QoWC
L3 5–6 marks	All bullet points in the question are covered in detail. The candidate shows good knowledge and uses the technical terms correctly. The answer has structure and clearly conveys the information required by the question. The candidate may show a depth of understanding that goes beyond basic recall and will appreciate the impact of the technology on society.	The student presents relevant information coherently, employing structure, style and sp&g to render meaning clear. The text is legible.
L2 3–4 marks	All of the main processes are addressed and most of the detail is present. There may be an understanding of the impact of the technology on society. There will be some structure, but may be brief or unclear in parts.	The student presents relevant information and in a way which assists the communication of meaning. The text is legible. Sp&g are sufficiently accurate not to obscure meaning.
L1 1–2 marks	A limited answer with significant detail missing. The impact on society may be stated basically but not developed. Candidates may be able to recall some technical terms, but these may be used without expansion or understanding. The material may lack organisation.	The student presents some relevant information in a simple form. The text is usually legible. Sp&g allow meaning to be derived although errors are sometimes obstructive.
0	The work contains no significant analysis of the question asked.	The student's presentation, spelling, punctuation and grammar seriously obstruct understanding.

Expected information:

Quantisation – the conversion of a continuously varying voltage level by sampling into one that contains discrete (stepped) voltage levels

Factors affecting quality of conversion

i) Sampling rate:

- The number of times/second that the analogue signal is assigned a digital code
- Audio requires a sample rate = 2 × highest frequency component ----- (**Nyquist rate**)
- Under sampling will cause a loss in quality. ----- (**Aliasing**)
- Over sampling results in superfluous data

ii) Size of digital code:

- Number of bits per sample determines smallest change in analogue signal that can cause a change in digital code – -----
resolution
- **CD** – standard is 16 bits

The combination of these two factors will determine the amount of data generated in the conversion process. The quantity of data will be very large and will probably require compression techniques to be applied

Advantages of a digital format:

- Good noise immunity
- Digital recordings don't degrade with frequent use in the same way as analogue recordings (Tape v CD)
- Digital files can be saved and manipulated by computer
- Can be coded for downloading across the Internet

Disadvantages of a digital format

- Can be conceived as being too clinical
- Data can become corrupt
- Format compatibility issues

Further points:

Why digital is dominant format in the recording industry

- V. good digital system is cheaper than v. good analogue system
- Scratch resistant format even on CDs
- Development of small personal music devices
- Development of downloads using personal computer
- Development of higher density storage devices (CD to SSD)

[6]

4. (a) Period $T (= 11.3 - 3.2) = 8.1 \pm 0.2 \text{ ms.}$ ✓

Number of revolutions per second $\left(= \frac{1}{T} = \frac{1}{8.1 \times 10^{-3}} \right) = 120 (\pm 10) \text{ (rev s}^{-1}\text{).}$ ✓

(b) Signal is noisy **OR** output is not at appropriate levels for logic circuit. ✓

1

(c) $V_A \left(= \frac{12}{12+8.2} \times 5 \right) = (+)2.97V \checkmark$

1

(d) Output pd switches between 0 and +5V. ✓

Output pd is inverted compared to input pd. ✓

Waveform has vertical sides cutting curve at about 3V. ✓

MAX 2

[6]

5.

(a) upper audio frequency maximum 15–20kHz ✓

sampling frequency must be higher ✓ than 2x ✓ highest audio frequency

3

(b) 65536 ✓

allow 65535

1

(c) $5 / 65535 \checkmark = 76\mu V \checkmark$

allow 65536

ecf from (b)

2

(d) high & low frequencies are lost *or* reduced bandwidth ✓

reference to perceived quality, e.g. lack of bass / treble in the music, 'tinny', or similar

✓

2

[8]