

**Q1.(a)** Explain what is meant by the coefficient of performance of a heat pump.

.....

.....

.....

.....

(1)

(b) The box labelled **E** in the figure below shows a diagram of a combined heat and power scheme. The scheme provides electrical energy  $W$  from an engine-driven generator and heat  $Q_1$  for buildings situated near to the generator.

Some of the electrical energy is used to drive the heat pump shown in the box labelled **P**. Output  $Q_2$  is also used to heat the buildings.

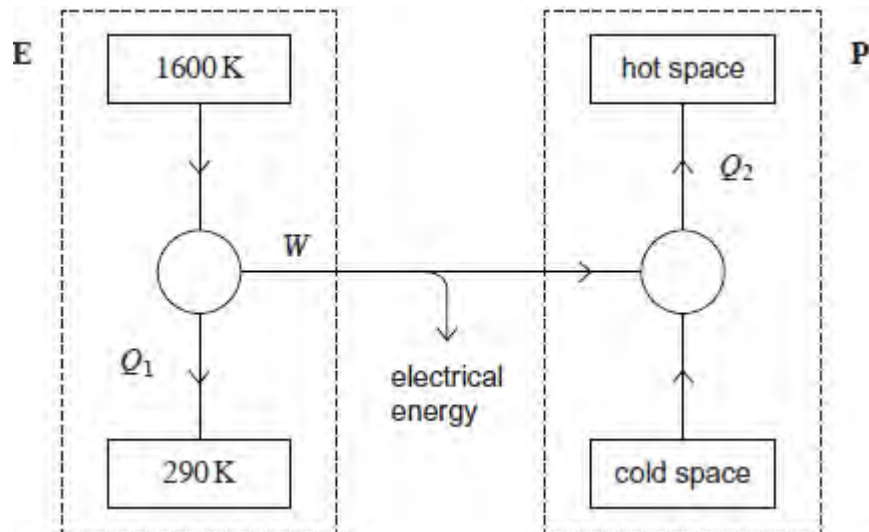

You may assume that the engine runs at its maximum theoretical efficiency and that the electrical generator is 100% efficient. The output power of the engine-driven generator is 80 kW.

(i) The fuel used in the engine (**E**) is propane of calorific value  $49 \text{ MJ kg}^{-1}$ . Calculate the rate of flow of propane into the engine. State an appropriate unit.

rate of flow ..... unit .....

(4)

- (ii) The heat pump has a coefficient of performance of 2.6. The power supplied by the electrical generator to the heat pump (**P**) is 16 kW. Calculate the total rate at which energy is available for heating from both the engine and heat pump.

rate at which energy is available ..... W

(3)

- (iii) The conversion of electrical energy to heat is nearly 100% efficient. Explain why the designer has proposed installing a heat pump rather than an electrical heater to provide the additional heat  $Q_2$ .

.....

.....

.....

.....

.....

(2)

(Total 10 marks)

**Q2.(a)** Explain what is meant by a reversed heat engine.

.....

.....

.....

.....

(2)

- (b) Explain why the coefficient of performance of a reversed heat engine when operating as a heat pump is always greater than the coefficient of performance of the same reversed heat engine when operating as a refrigerator.

.....

.....

.....

.....

.....

.....

(2)  
(Total 4 marks)

- Q3.** (a) The coefficient of performance of a refrigerator is given by

$$COP_{ref} = \frac{Q_{out}}{Q_{in} - Q_{out}}$$

With reference to a refrigerator, explain the terms  $Q_{in}$  and  $Q_{out}$ .

.....

.....

.....

.....

(2)

- (b) A refrigerator is designed to make ice at  $-10\text{ }^\circ\text{C}$  from water initially at room temperature. The energy needed to make 1.0 kg of ice at  $-10\text{ }^\circ\text{C}$  from water initially at room temperature is 420 kJ. The refrigerator has a coefficient of performance of 4.5.

- (i) Calculate the power input to the refrigerator if it is required to make 5.5 kg of ice every hour.

answer = ..... W

(2)

- (ii) Calculate the rate at which energy is delivered to the surroundings of the refrigerator.

answer = ..... W

(1)  
(Total 5 marks)