

Q1. During the spin part of a washing machine programme the maximum rotational speed is 126 rad s^{-1} ($1200 \text{ rev min}^{-1}$). The moment of inertia of the drum and washing at the start of the spin part of the cycle is 0.565 kg m^2 . Assume that the wet washing is evenly distributed around the drum as shown in **Figure 1**.

Figure 1

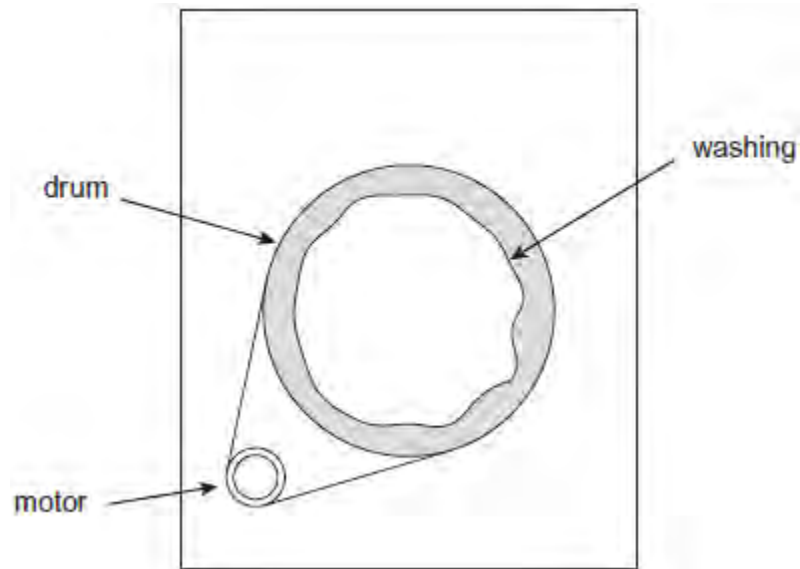

- (a) **Figure 2** shows the variation of angular speed with time for the spin part of the cycle. The graph is not drawn to scale.

Figure 2

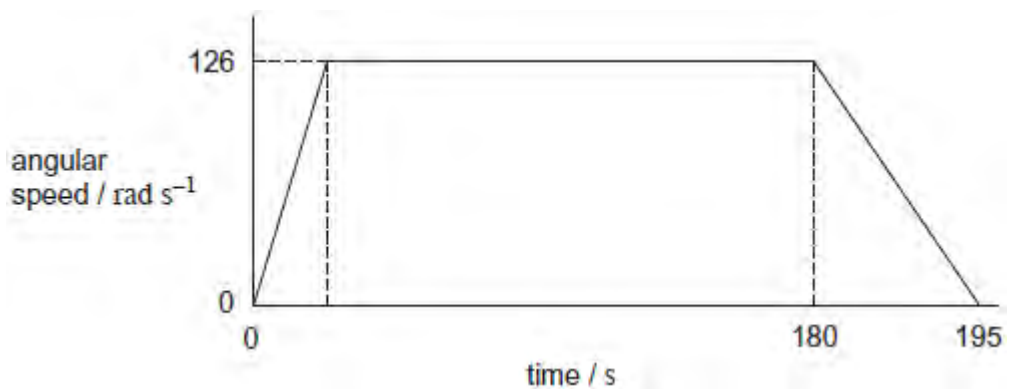

The motor provides a torque of 8.80 N m to accelerate the drum to 126 rad s^{-1} . The drum rotates at 126 rad s^{-1} until near the end of the spin cycle, when the drum decelerates uniformly to zero angular speed in 15 seconds. Friction at the bearings

may be neglected. Assume that during acceleration the moment of inertia of the drum and washing remains constant.

- (i) Show that the drum accelerates for about 8 s.

(2)

- (ii) Calculate the total number of revolutions made by the drum during the 195 s shown in **Figure 2**.

number of revolutions =

(3)

- (b) (i) In practice, at the start of the cycle the acceleration will not remain constant. Draw on **Figure 2** a line to show how the initial part of the graph will change.

(1)

- (ii) Explain your reasons for the line you have drawn.

.....
.....
.....
.....
.....

(2)

Q2.Figure 1 shows a satellite with three solar panels folded in close to the satellite's axis for the journey into space in the hold of a cargo space craft.

Figure 1

Figure 2

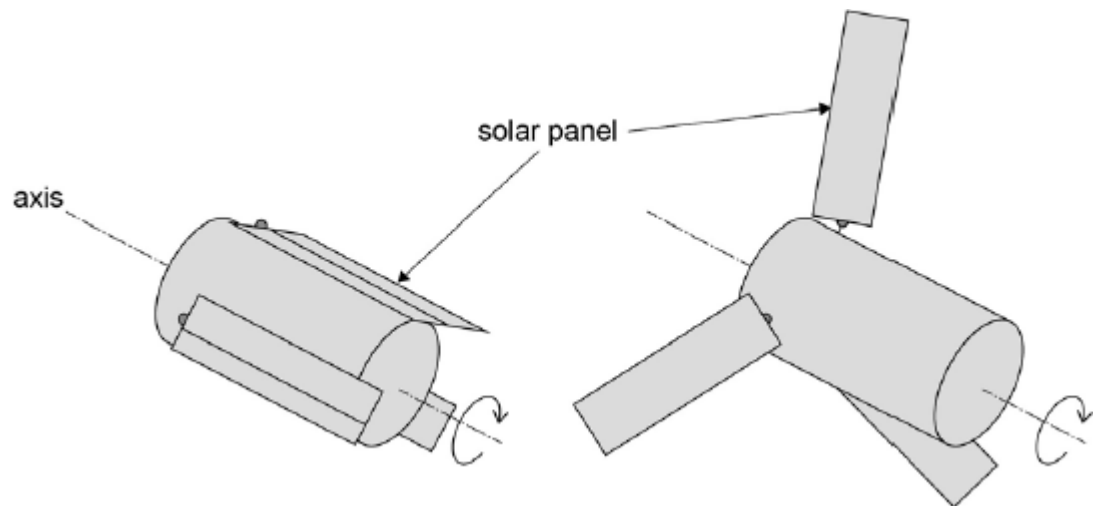

Just before it is released into space, the satellite is spun to rotate at 5.2 rad s^{-1} . Once released, the solar panels are extended as shown in **Figure 2**.

moment of inertia of the satellite about its axis with panels folded = 110 kg m^2

moment of inertia of the satellite about its axis with panels extended = 230 kg m^2

(a) State the law of conservation of angular momentum.

.....
.....
.....

(1)

(b) The total mass of the satellite is 390 kg and the solar panels each have a mass of 16 kg.

State what is meant by moment of inertia and explain why extending the solar panels changes the moment of inertia of the satellite by a large factor.

.....

.....
.....

(3)

- (c) Calculate the angular momentum of the satellite when it is rotating at 5.2 rad s^{-1} with the solar panels folded. State an appropriate unit for your answer.

angular momentum = unit

(2)

- (d) Calculate the angular speed of the satellite after the solar panels have been fully extended.

angular speed = rad s^{-1}

(2)

(Total 8 marks)

Q3. The following figure shows a motor-driven winch for raising loads on a building site. As the motor turns the cable is wound around the drum, raising the load.

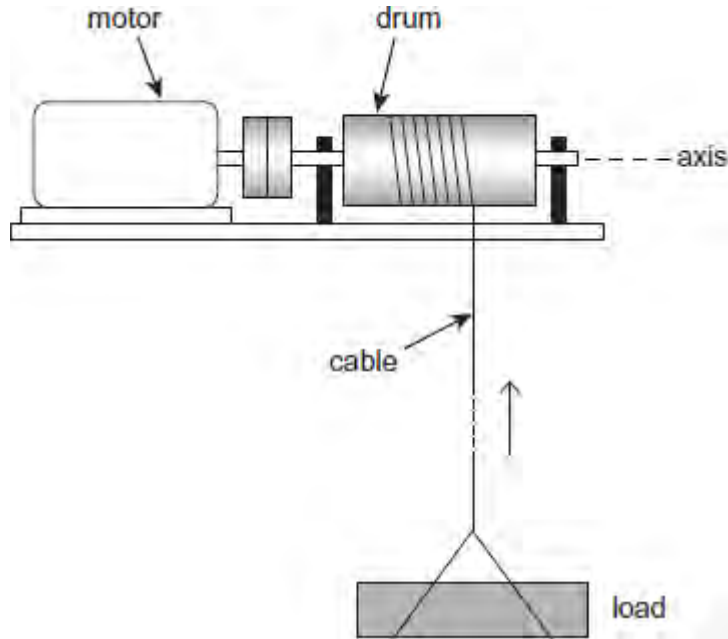

The drum, axle and other rotating parts have a moment of inertia about the axis of rotation of 7.4 kg m^2 , and the mass of the load is 85 kg . The drum has a radius of 0.088 m .

The load is accelerated uniformly from rest to a speed of 2.2 m s^{-1} . When it is accelerating it rises through a height of 3.5 m . It then continues at the constant speed of 2.2 m s^{-1} .

- (a) Show that the drum turns through 40 rad as the load accelerates.

(1)

- (b) Calculate the angular speed of the drum when the load is moving at 2.2 m s^{-1} .

angular speed rad s^{-1}

(1)

- (c) (i) Show that for the time that the load is accelerating the total increase in energy of the load and the rotating parts is about 5400 J .

(3)

- (ii) A constant frictional torque of 5.2 N m acts at the bearings of the winch.
Calculate the total work done by the motor to accelerate the load.
Give your answer to an appropriate number of significant figures.

total work done J

(3)

- (d) Calculate the **maximum** power developed by the motor.

maximum power W

(2)

(Total 10 marks)