



GCSE Physics
Transformers and The
National Grid
Question Paper

Time available: 65 minutes
Marks available: 59 marks

www.accesstuition.com

1.

A student used a simple transformer to investigate how the number of turns on the secondary coil affects the potential difference (p.d.) across the secondary coil. The student kept the p.d. across the primary coil fixed at 2V.

Figure 1 shows the results collected by the student.

Figure 1

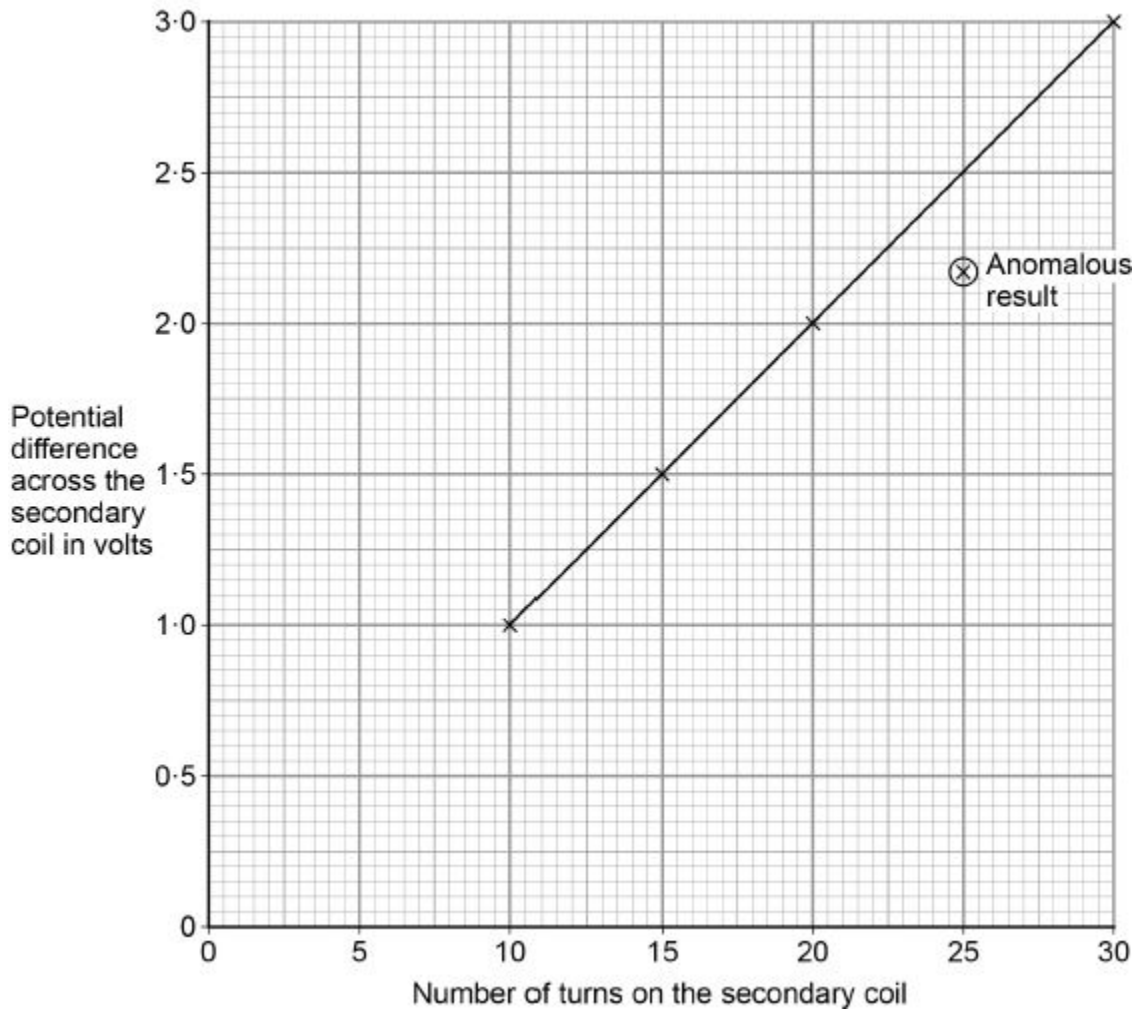

(a) Figure 1 contains one anomalous result.

Suggest **one** possible reason why this anomalous result occurred.

(1)

(b) The transformer changes from being a step-down to a step-up transformer.

How can you tell from **Figure 1** that this happens?

(1)

A spot-welder is a device that uses a transformer to produce a large current to join sheets of metal together.

Figure 2 shows a transformer demonstrating how a large current can heat and join two nails together.

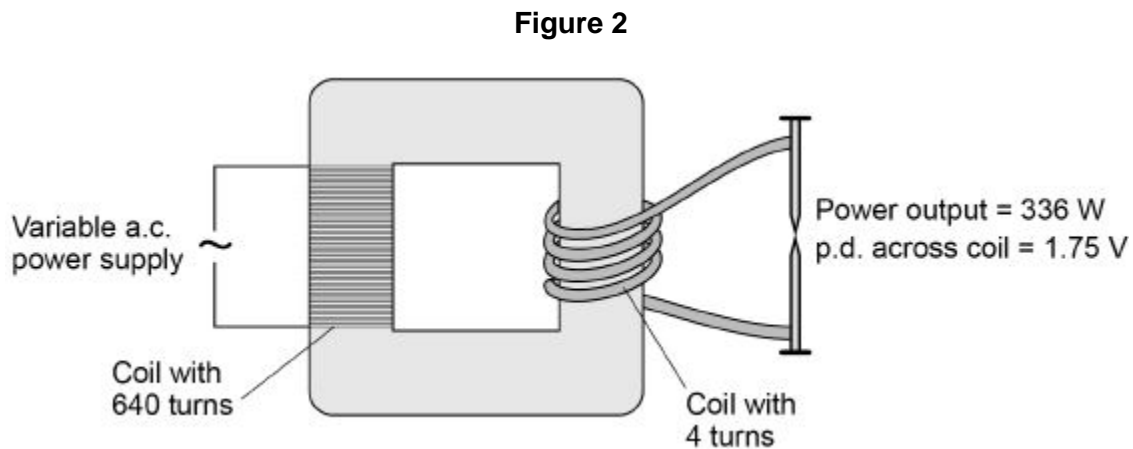

(c) How does the amount of infrared radiation emitted by the nails change when the power supply is switched on?

(1)

(d) Calculate the current from the power supply needed to provide a power output of 336 W.

Use the data in **Figure 2**.

The transformer is 100% efficient.

Current = _____ A

(5)
(Total 8 marks)

2. **Figure 1** shows the construction of a simple transformer.

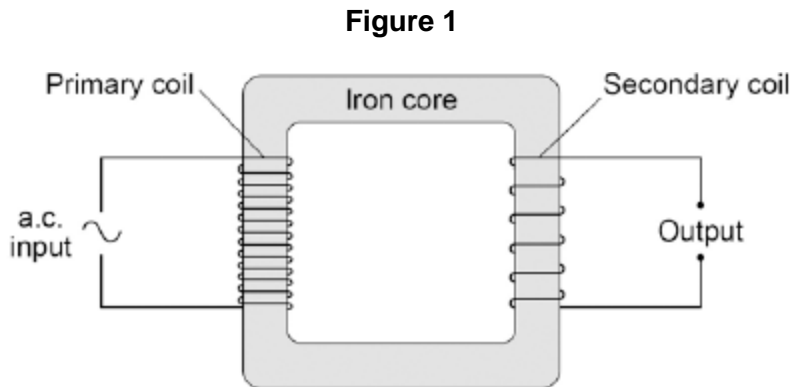

(a) Why is iron a suitable material for the core of a transformer?

Tick **one** box.

It is a metal.

It will not get hot.

It is easily magnetised.

It is an electrical conductor.

(b) A student makes three simple transformers, **J**, **K** and **L**.

Figure 2 shows how the potential difference across the secondary coil of each transformer varies as the potential difference across the primary coil of each transformer is changed.

Figure 2

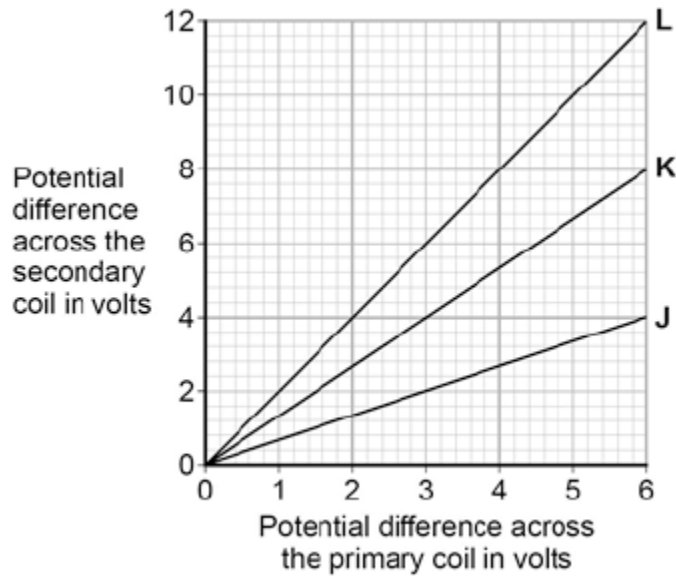

How can you tell that transformer **J** is a step-down transformer?

(1)

(c) Each of the transformers has 50 turns on the primary coil.

Calculate the number of turns on the secondary coil of transformer **L**.

Use the correct equation from the Physics Equations Sheet.

Number of turns on the secondary coil = _____

(3)

(Total 5 marks)

3.

Figure 1 shows the structure of a traditional transformer.

Figure 1

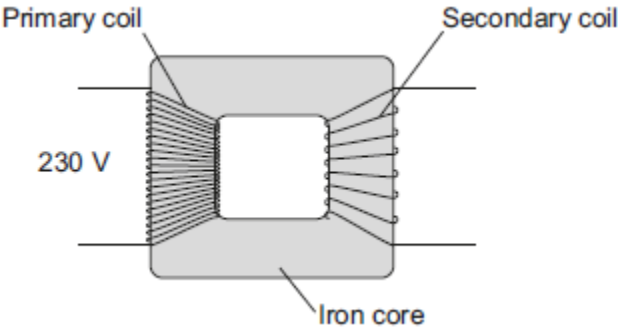

(a) There is an alternating current in the primary coil of the transformer.

State what is produced in the iron core.

(2)

(b) A transformer has only **one** turn of wire on the secondary coil.
The potential difference across the secondary coil is 11.5 V
The potential difference across the primary coil is 230 V

Calculate the number of turns on the primary coil.

Number of turns on the primary coil = _____

(2)

(c) In most transformers, the power output is less than the power input.

State why.

(1)

- (d) Two students investigated how magnets can be used to produce a potential difference. The students held a coil of wire above a magnet. The students quickly lowered the coil so that the magnet was inside the coil, as shown in **Figure 2**.

Figure 2

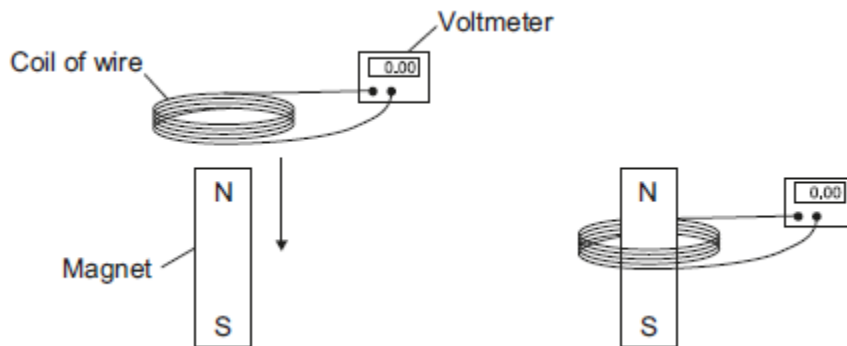

The students recorded the maximum potential difference for coils with different numbers of turns of wire. The results are shown in the table.

Number of turns of wire in the coil	Maximum potential difference in volts	
	Results from student 1	Results from student 2
5	0.09	0.08
10	0.20	0.15
15	0.31	0.25
20	0.39	0.33
25	0.51	0.39

- (i) State the resolution of the voltmeter.

Give **one** reason why the resolution of the voltmeter is suitable for this investigation.

Resolution _____

Reason _____

(2)

- (ii) The two students used exactly the same equipment to carry out their investigations. Both students recorded their results correctly.

Give the reason why student 2 got different results from student 1.

(1)

- (iii) The students decided that even though the results were different, there was no need to repeat the investigation.

How do the results show that the investigation is reproducible?

(1)

- (iv) State the name of the process which causes the potential difference to be produced in this investigation.

(1)

- (e) A transformer has been developed that can be used with many different devices.

Suggest **one** advantage of having a transformer that can be used with many different devices.

(1)

(Total 11 marks)

4.

An electric toothbrush is charged by standing it on a separate charging base. The diagram shows the inside of the electric toothbrush and the charging base.

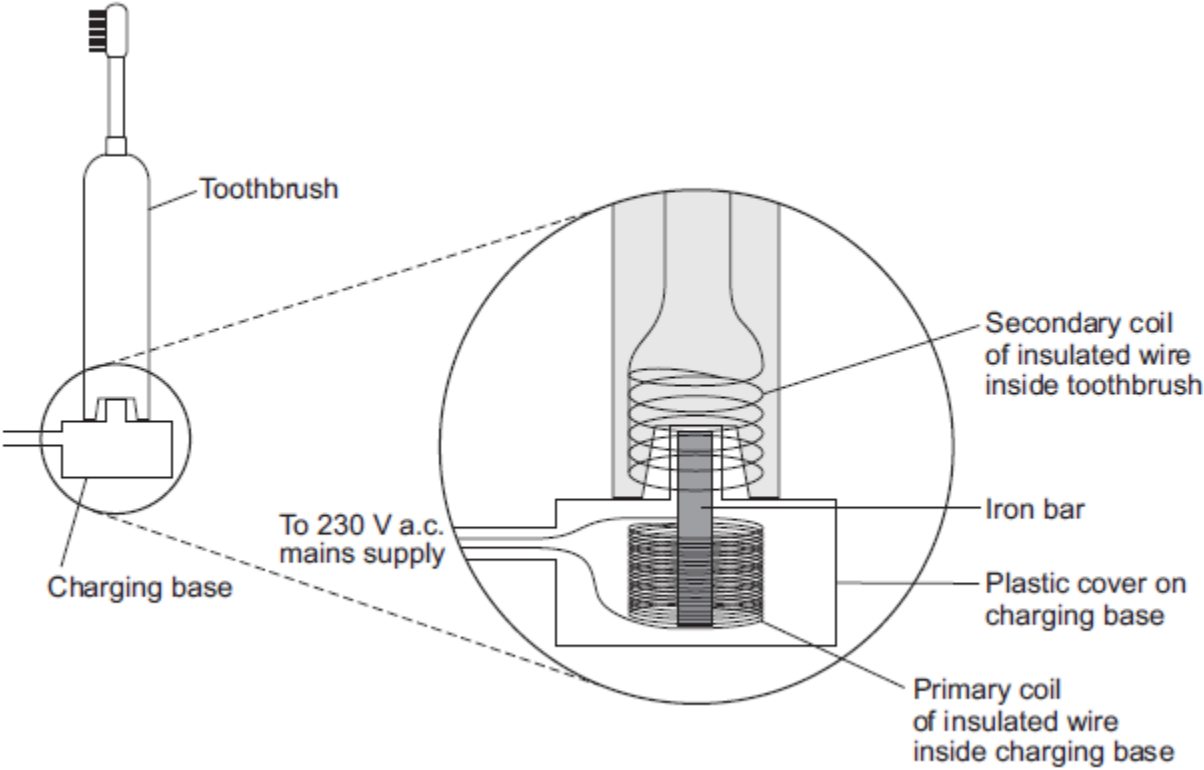

(a) An alternating potential difference (p.d.) across the coil in the charging base creates an alternating current in the coil inside the toothbrush.

Explain how.

(3)

- (b) When the toothbrush is being charged, the p.d. across the primary coil in the charging base is 230 V.

The charging p.d. across the secondary coil in the toothbrush is 7.2 V.

The primary coil in the charging base has 575 turns of wire on its coil.

Calculate the number of turns on the secondary coil inside the toothbrush.

Number of turns on the secondary coil = _____

(2)

(Total 5 marks)

5.

Figure 1 shows a traditional transformer.

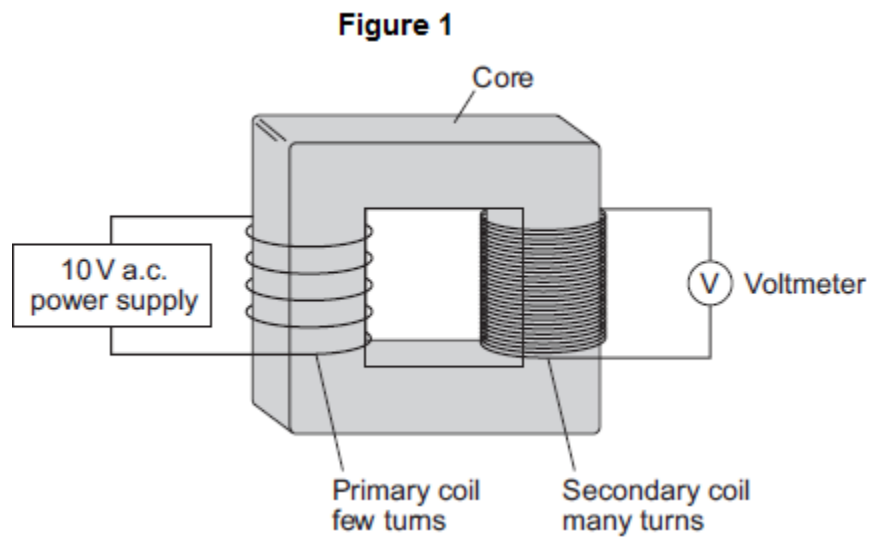

(a) (i) Which metal should the core of the transformer be made from?

Tick (✓) **one** box.

- aluminium
- copper
- iron

(1)

(ii) What would the reading be on the voltmeter shown in **Figure 1**?

Draw a ring around the correct answer.

2 V

10 V

50 V

Give the reason for your answer.

(2)

(b) **Figure 2** shows a tablet computer and its charger.

Figure 2

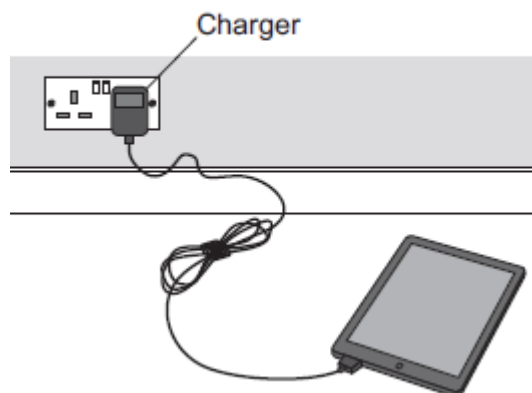

The charger contains a switch mode transformer.

- (i) Use the correct answer from the box to complete the sentence.

200	1000	20 000
------------	-------------	---------------

Switch mode transformers operate at frequencies

from 50 kHz to _____ kHz.

(1)

- (ii) Give **one** advantage of a switch mode transformer over a traditional transformer.

(1)

(Total 5 marks)

7.

The diagram shows a transformer with a 50 Hz (a.c.) supply connected to 10 turns of insulated wire wrapped around one side of the iron core.

A voltmeter is connected to 5 turns wrapped around the other side of the iron core.

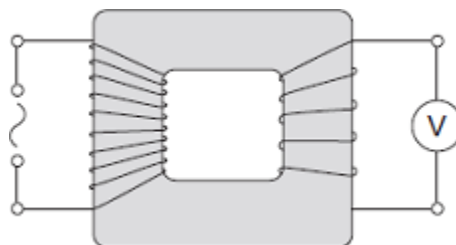

(a) What type of transformer is shown in the diagram?

Draw a ring around the correct answer.

step-down

step-up

switch mode

(1)

(b) The table shows values for the potential difference (p.d.) of the supply and the voltmeter reading.

p.d. of the supply in volts	Voltmeter reading in volts
6.4	3.2
3.2	
	6.4

(i) Complete the table.

(2)

(ii) Transformers are used as part of the National Grid.

How are the values of p.d. in the table different to the values produced by the National Grid?

(1)

(c) Transformers will work with an alternating current (a.c.) supply but will **not** work with a direct current (d.c.) supply.

(i) Describe the difference between a.c. and d.c.

(2)

(ii) Explain how a transformer works.

(4)

(Total 10 marks)

8.

(a) In the National Grid, very large step-up transformers link power stations to the transmission cables.

A transformer used for this purpose has 800 turns on its primary coil and 12 800 turns on its secondary coil. The p.d. (potential difference) across its primary coil is 25 kV.

Use the equation in the box to calculate the p.d. across its secondary coil.

$$\frac{\text{p.d. across primary}}{\text{p.d. across secondary}} = \frac{\text{number of turns on primary}}{\text{number of turns on secondary}}$$

Show clearly how you work out your answer.

p.d. across secondary coil = _____ volts

(2)

(b) The diagram shows the structure of a transformer.

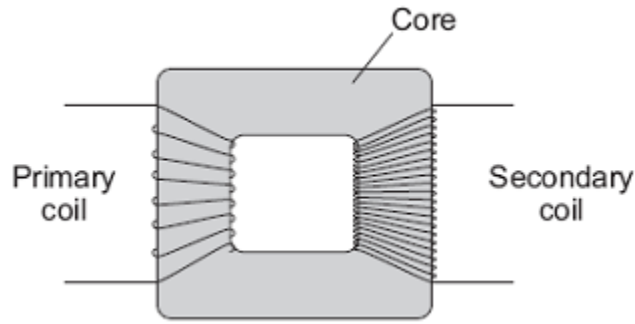

(i) The primary and secondary coils of a transformer are made of insulated wire.

Why is this insulation necessary?

(1)

(ii) Why is the core made of iron?

(1)

(iii) Explain how the transformer works.

(3)

- (c) Before 1926, large towns had their own local power stations. After 1926, these power stations were connected to form the National Grid.

Give **two** advantages of having a National Grid system.

1. _____

2. _____

(2)
(Total 9 marks)