

## Using light emitting diodes (LEDs)

1 (a) What is the name of the device used to change the size of an alternating voltage?

(1)

(b) A light emitting diode (LED) can only emit light when connected correctly to a potential difference.

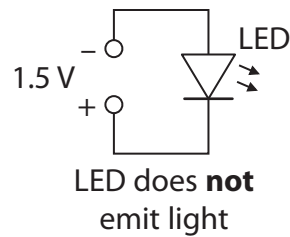
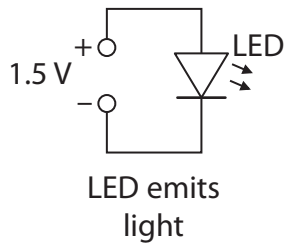

Use this information to suggest what happens when this alternating voltage is connected across the LED.

(2)

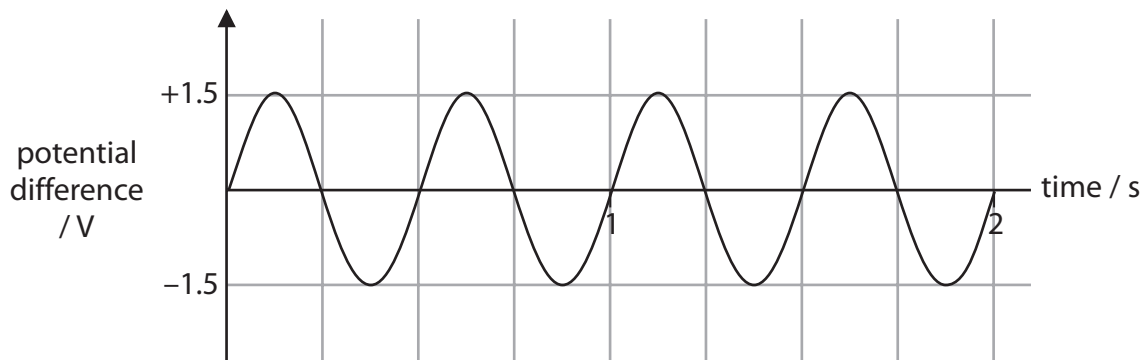

---

---

---

---

- (c) A LED lamp has a power rating of 3 W.  
The voltage across the lamp is 12 V.  
Calculate the current in the lamp.

(3)

current in the lamp = ..... A

- \*(d) Some research has been carried out into replacing fluorescent lamp fittings with LED fittings.



photo of stairwell  
with fluorescent fitting



photo of stairwell  
with LED fitting

The data in the table is taken from the report of a trial using LEDs to light stairwells and corridors in a large building.

total energy saved each year by using LEDs	3 000 kW h
LED fitting cost	£2 000
CO <sub>2</sub> saving each year by using LEDs	1.6 tonnes
change in lighting levels by using LEDs	200%
average price of electrical energy	14 p / kW h
average lifetime of LED fittings	50 000 hours
average lifetime of fluorescent fittings	10 000 hours

Use the information to discuss the benefits of replacing fluorescent fittings with LED fittings.

(6)

.....

.....

.....

.....

.....

.....

.....

.....

.....

.....

.....

.....

.....

.....

.....

.....

.....

.....

.....

.....

.....

.....

.....

---

**(Total for Question 6 = 12 marks)**

## Controlling electric current

- 2 An inventor is designing a battery-powered torch. She wants the torch to have a brightness control.

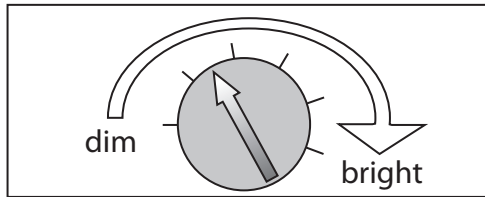

brightness control

- (a) Which of these could she use in this control?

Put a cross (☒) in the box next to your answer.

(1)

- A a diode
- B a light-dependent resistor
- C a thermistor
- D a variable resistor

- (b) She builds this circuit to test the lamp in the torch.

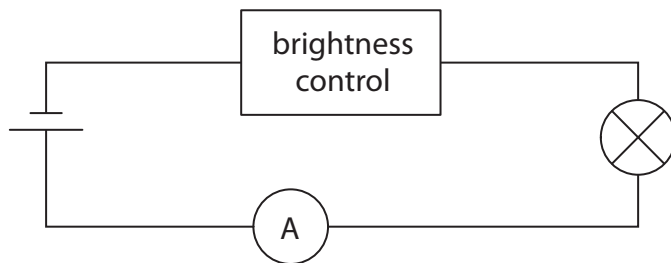

- (i) Add a voltmeter to the circuit which will measure the potential difference (voltage) across the lamp.

(1)

(ii)

$$R = \frac{V}{I}$$

She sets the control at the "bright" position.

The current is 0.26 A and the potential difference (voltage) across the lamp is 6.0 V.

Calculate the resistance of the lamp.

(2)

resistance of the lamp = .....  $\Omega$

(c) The inventor takes readings of the potential difference (voltage) across the lamp and the current at different positions of the control from "dim" to "bright".

	dim					bright
voltage / V	0.6	1.1	2.0	2.7	3.9	6.0
current / A	0.07	0.10	0.14	0.17	0.21	0.26

She plots a graph of the readings.

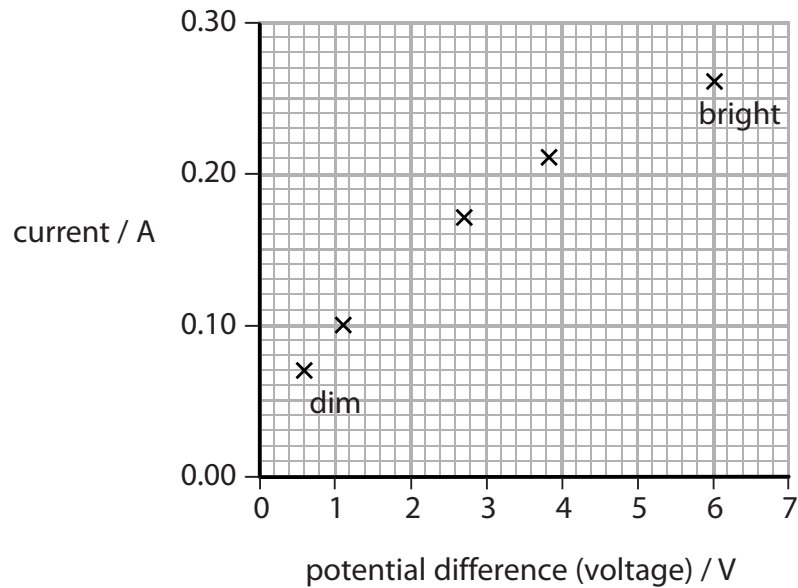

(2)

(ii) Describe what this graph shows about how the current changes as the voltage changes.

(2)

.....

.....

.....

.....

.....

.....

(iii) The lamp gives no light when the brightness control is at its lowest setting.  
Suggest why the torch would still need an on/off switch as well as the brightness control.

(2)

.....

.....

.....

.....

**(Total for Question 3 = 10 marks)**

### Electric current and temperature

- 3 (a) A designer is going to use a thermistor in a temperature gauge. He connects the thermistor into this circuit.

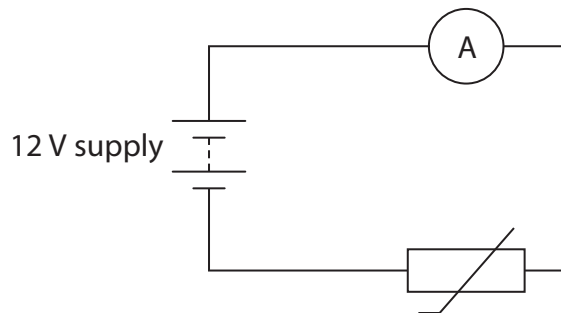

He heats the thermistor and measures the current at different temperatures. Here are some of the results plotted on a graph.

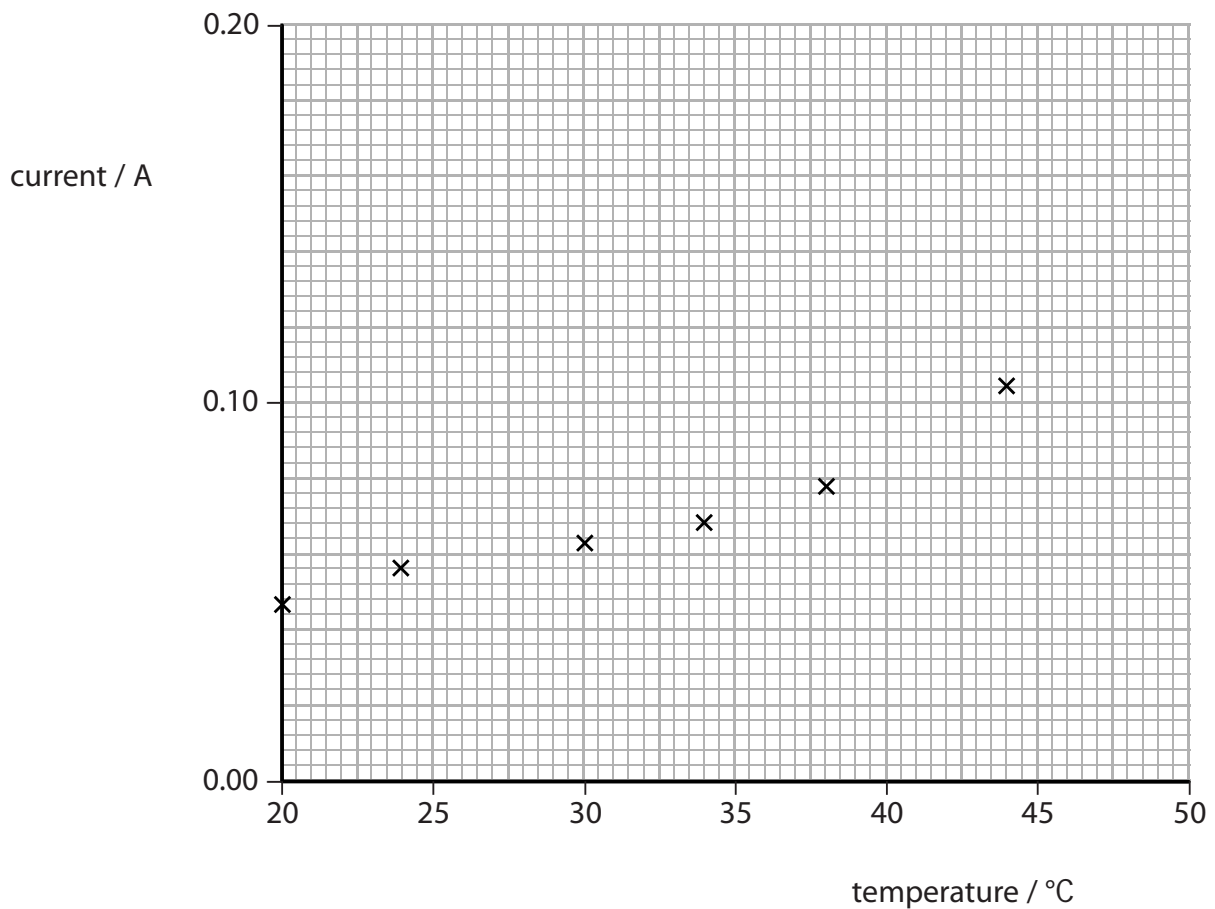

At 47 °C the current was 0.138 A.

- (i) Plot this value on the graph. (1)
- (ii) Draw the curve of best fit through the points. (1)

- (iii) The supply voltage is 12 V.  
At 20 °C the current is 0.047 A.

Calculate the resistance of the thermistor at this temperature.

(3)

resistance = .....  $\Omega$

- (iv) Use this graph of current against temperature to explain the relationship between resistance and temperature for this thermistor.

(2)

.....

.....

.....

.....

- (b) (i) When there is an electric current in a resistor, the resistor gets hot.

Explain why the resistor gets hot.

(2)

.....

.....

.....

.....

- (ii) Suggest why the thermistor in a temperature gauge might indicate a temperature slightly higher than the actual temperature of its surroundings.

(1)

.....

.....

.....

---

**(Total for Question 3 = 10 marks )**



## Circuits

4 (a) (i) Draw **one** straight line from each name to its circuit symbol.

(2)

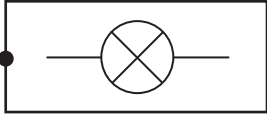
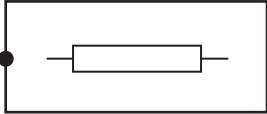
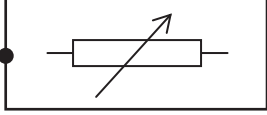
name	circuit symbol
<div style="border: 1px solid black; padding: 5px; display: inline-block;">lamp</div>	
<div style="border: 1px solid black; padding: 5px; display: inline-block;">fixed resistor</div>	
	

(ii) The diagram shows an incomplete circuit for measuring the resistance of a length of wire.

Complete the diagram to show how an ammeter,  $\text{---}(\text{A})\text{---}$ , and a voltmeter,  $\text{---}(\text{V})\text{---}$ , should be connected in the circuit.

(2)

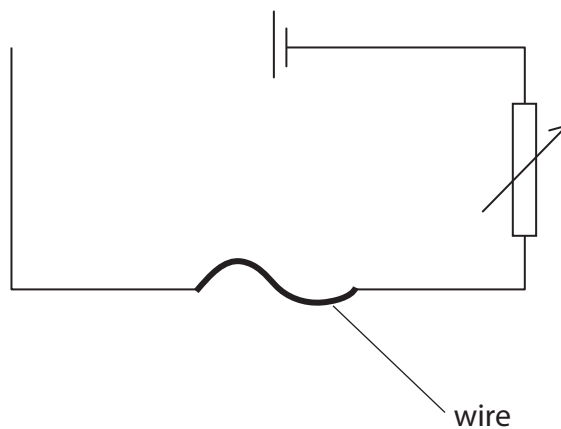

- (b) A student sets up a circuit to find the resistance of a piece of wire. She measured current and voltage at different voltage settings.

She plotted a graph of her results.

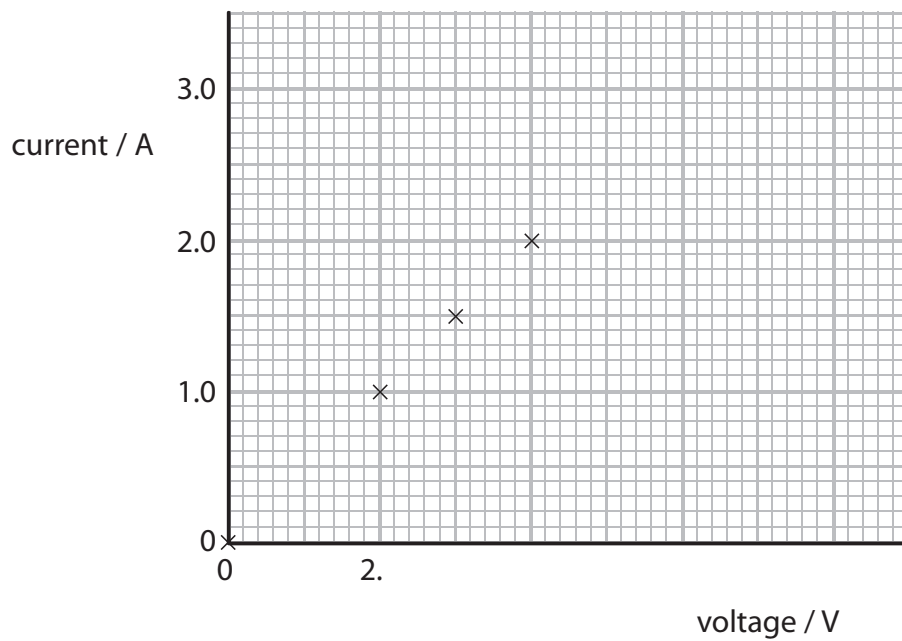

- (i) Draw the line of best fit for these four points.

(1)

- (ii) She then took an extra reading and found that a voltage of 7.0 V gave a current of 3.0 A.

Plot this point on the graph.

(1)

(iii) She decides to take an additional reading.

This is to help her reach a conclusion about the way current changes with voltage.

Explain which additional reading she could take.

(2)

.....

.....

.....

.....

(iv) 
$$R = \frac{V}{I}$$

Calculate the resistance of the piece of wire when the current is 1.5 A.

(3)

resistance = .....  $\Omega$

**(Total for Question 4 = 11 marks)**