

Please write clearly in block capitals.

Centre number

--	--	--	--	--

Candidate number

--	--	--	--

Surname

Forename(s)

Candidate signature

GCSE MATHEMATICS

H

Higher Tier

Paper 1 Non-Calculator

Tuesday 6 November 2018

Morning

Time allowed: 1 hour 30 minutes

Materials

For this paper you must have:

- mathematical instruments

You must **not** use a calculator.

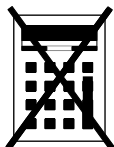

Instructions

- Use black ink or black ball-point pen. Draw diagrams in pencil.
- Fill in the boxes at the top of this page.
- Answer **all** questions.
- You must answer the questions in the spaces provided. Do not write outside the box around each page or on blank pages.
- Do all rough work in this book. Cross through any work you do not want to be marked.

Information

- The marks for questions are shown in brackets.
- The maximum mark for this paper is 80.
- You may ask for more answer paper, graph paper and tracing paper. These must be tagged securely to this answer book.

Advice

In all calculations, show clearly how you work out your answer.

For Examiner's Use

Pages	Mark
2–3	
4–5	
6–7	
8–9	
10–11	
12–13	
14–15	
16–17	
18–19	
20–21	
22–23	
TOTAL	

Answer **all** questions in the spaces provided

- 1 Simplify $(5^4)^2$
Circle your answer.

[1 mark]

5^6

5^8

25^6

25^8

- 2 Circle the volume, in cm^3 , of a cylinder with radius 5 cm and height 8 cm

[1 mark]

40π

80π

200π

1600π

- 3 Simplify $16a^2 \div a + 3a \times 2$
Circle your answer.

[1 mark]

$22a$

$8a$

$38a$

$2a$

4 Circle the value of $\cos 30^\circ$

[1 mark]

$$\frac{1}{2}$$

$$\frac{\sqrt{3}}{2}$$

$$0$$

$$1$$

5 Work out $8\frac{1}{2} \div 2\frac{2}{3}$

Give your answer as a mixed number.

[4 marks]

Answer _____

- 6 A ship is sailing in a straight line from its home port.
The distance-time graph shows 4 hours of the journey.

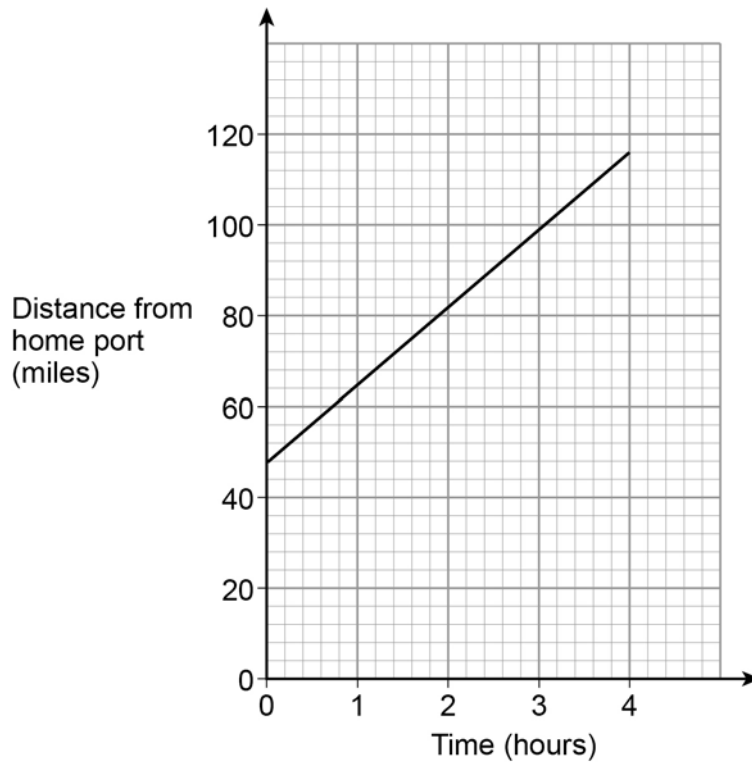

Work out the speed of the ship during these 4 hours.

[3 marks]

Answer _____ mph

- 7 The sum of the angles in any quadrilateral is 360°
For example, in a rectangle $4 \times 90^\circ = 360^\circ$

Zak writes,

$$5 \times 90^\circ = 450^\circ \text{ so the sum of the angles in any pentagon must be } 450^\circ$$

Is he correct?

Tick a box.

Yes

No

Show working to support your answer.

[2 marks]

Turn over for the next question

- 8** Kim works at an airport in the UK.
She records the number of planes landing between 10 am and 2 pm each day.
The table shows the data for the first 10 days in January.

Day	1	2	3	4	5	6	7	8	9	10
Number of planes	148	151	147	155	153	147	155	102	151	154

- 8 (a)** The airport was affected by fog on one of the days.

Which day do you think it was?
Give a reason for your answer.

[1 mark]

Day _____

Reason _____

- 8 (b)** Kim uses the data to predict how many planes will land at the airport in a year.

In her method, she

uses an estimate of 150 planes in each 4-hour period throughout the day
assumes the same number of planes each day.

Work out her prediction.

[3 marks]

Answer _____

- 8 (c)** In fact,
fewer planes land in winter than in summer
fewer planes land at night than during the day.

What does this tell you about Kim's prediction?

Tick **one** box.

Her prediction is too low

Her prediction is too high

Her prediction could be too low or too high

Give a reason for your answer.

[2 marks]

Turn over for the next question

9

$$\sqrt{6^2 + 8^2} = \sqrt[3]{125a^3}$$

Work out the value of a .**[4 marks]**

Answer _____

10

Work out the percentage increase from 80 to 280

[3 marks]

Answer _____ %

11

Here are four triangles.

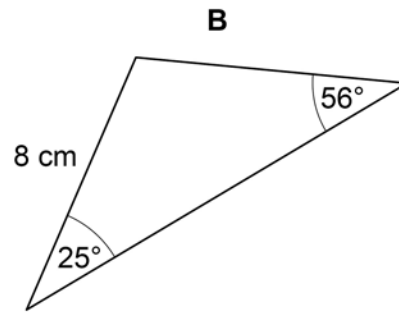
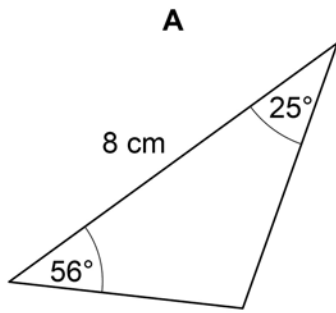
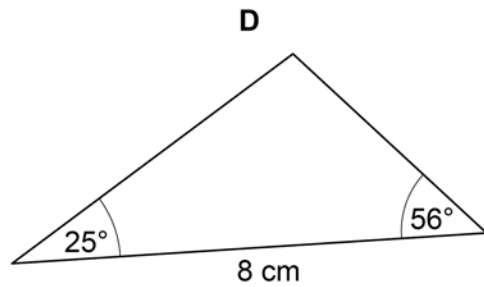
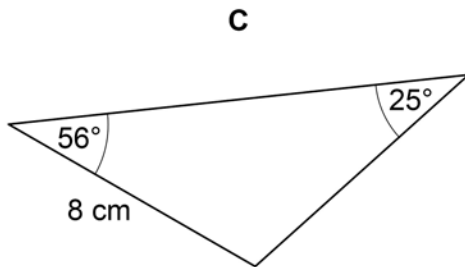
Not drawn
accurately

Which **two** triangles are congruent?
Circle **two** letters below.

[1 mark]

A

B

C

D

Turn over for the next question

Turn over ►

12 Solve $x^2 - x - 12 = 0$

[3 marks]

Answer _____

13 $e : f = 2 : 3$ and $f : g = 5 : 4$

Work out $e : g$

Give your answer in its simplest form.

[3 marks]

Answer _____ : _____

14

A and B are two events.

Some probabilities are shown on the Venn diagram.

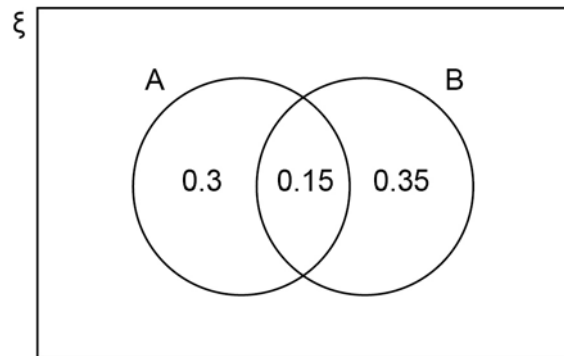
Work out $P(A' \cup B)$ **[2 marks]**

Answer _____

Turn over for the next question

15

In a survey, queuing times at supermarket checkouts were recorded.

One morning, samples of 50 customers were taken at supermarkets A, B, C and D.

The box plots represent the results.

Queuing times

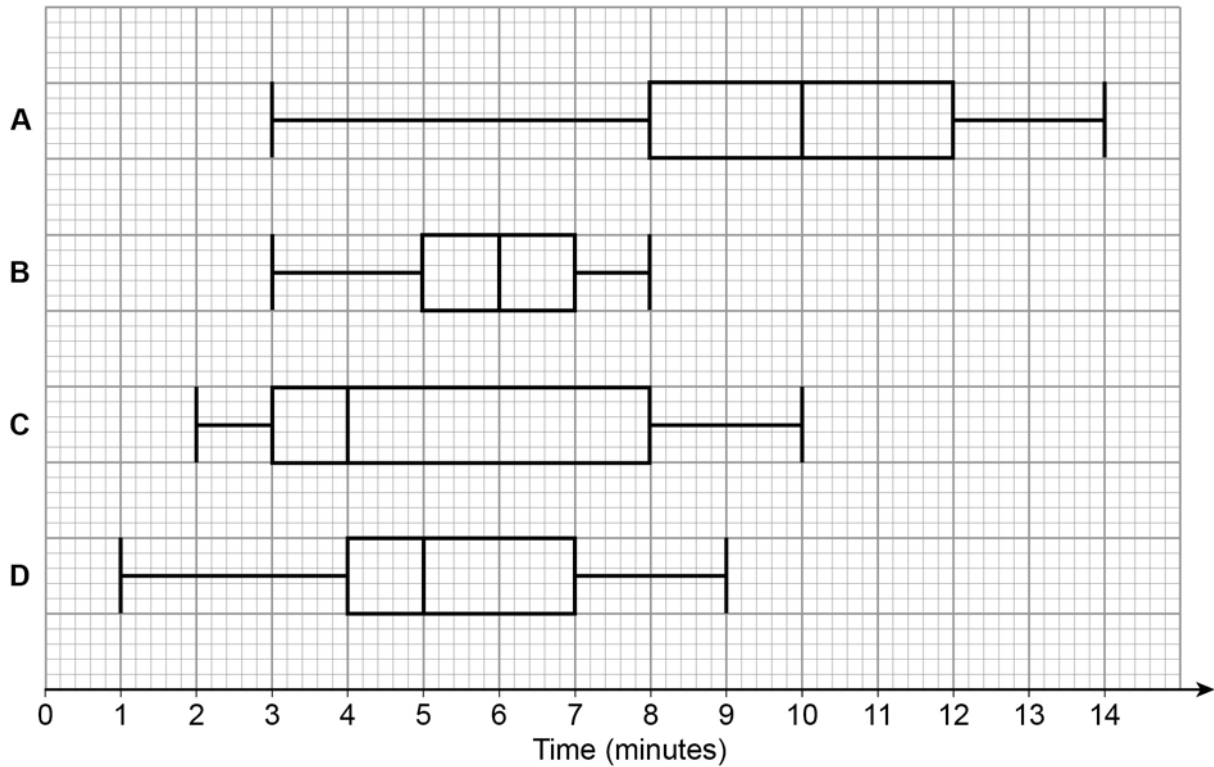

15 (a) On average, which supermarket had the lowest queuing times?

Give a reason for your answer.

[2 marks]

Supermarket _____

Reason _____

- 15 (b)** At which supermarket were the queuing times most consistent?
Give a reason for your answer.

[2 marks]

Supermarket _____

Reason _____

- 16** Circle the number that is closest to the value of 29^3

[1 mark]

27 000

90

2700

9000

- 17** Work out the exact value of $\left(\frac{3}{4}\right)^{-3}$

$$\left(\frac{3}{4}\right)^{-3}$$

[2 marks]

Answer _____

Turn over for the next question**Turn over ►**

18

Beth and Mia translate documents from Spanish into English.

A set of documents that would take Beth 8 days would take Mia 10 days.

Beth starts to translate the documents.

After 2 days Beth and Mia both work on translating the documents.

How many **more** days will it take to complete the work?

You **must** show your working.

[4 marks]

Answer _____ days

19 In a chess club, there are x boys and y girls.

19 (a) If 5 more boys and 8 more girls join, there would be half as many boys as girls.

Show that $y = 2x + 2$

[2 marks]

19 (b) If instead,
10 more boys and 1 more girl join, there would be the same number of boys and girls.

Work out x and y .

[3 marks]

$x =$

$y =$

20

P , Q , R and S are points on a circle.

PXR and QXS are straight lines.

$PX = SX$

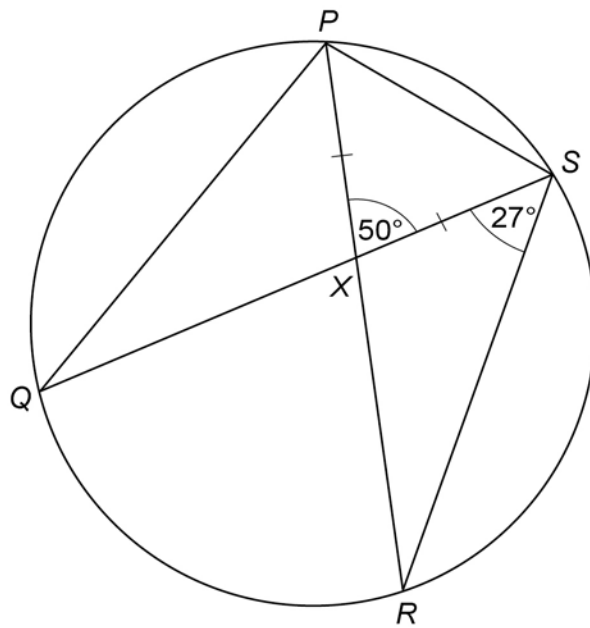

Not drawn
accurately

Prove that QS is **not** a diameter of the circle.

[4 marks]

21 Here are the first four terms of a quadratic sequence.

11 26 45 68

Work out an expression for the n th term.

[3 marks]

Answer _____

Turn over for the next question

23

Prisms A and B are similar.
The cross sections are shaded.

Prism A

volume = 480 cm^3

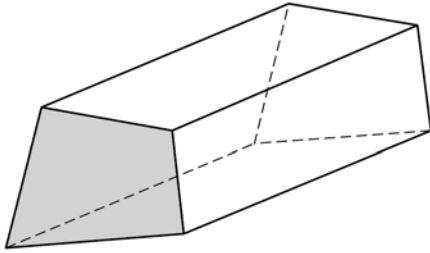

Prism B

length = 30 cm

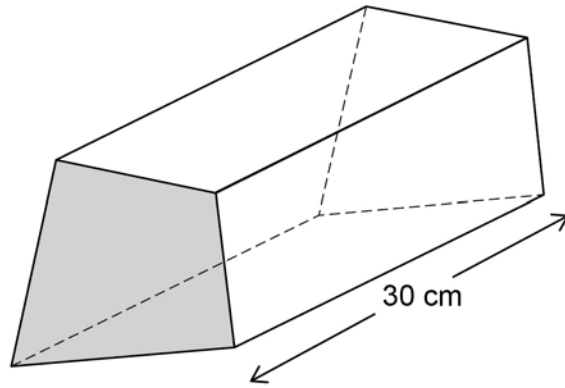

area of the cross section of A : area of the cross section of B = 4 : 9

Work out the area of the cross section of B.

[5 marks]

Answer _____ cm^2

24

Show that $\frac{2\sqrt{6}}{\sqrt{5}} - \frac{\sqrt{3}}{\sqrt{10}}$ can be written in the form $\frac{c\sqrt{d}}{10}$

where c and d are integers.

[3 marks]

25

A quadratic curve intersects the axes at $(-3, 0)$, $(3, 0)$ and $(0, 18)$

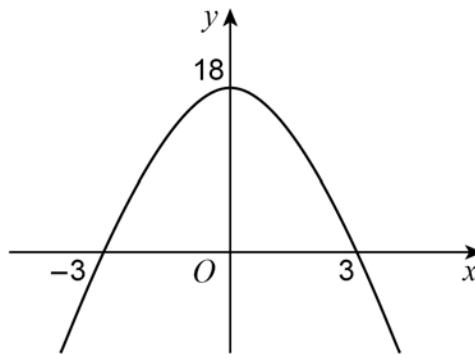

Not drawn
accurately

Work out the equation of the curve.

[3 marks]

Answer _____

Turn over for the next question

26

The area of this triangle is $25\sqrt{3}\text{ cm}^2$

Not drawn
accurately

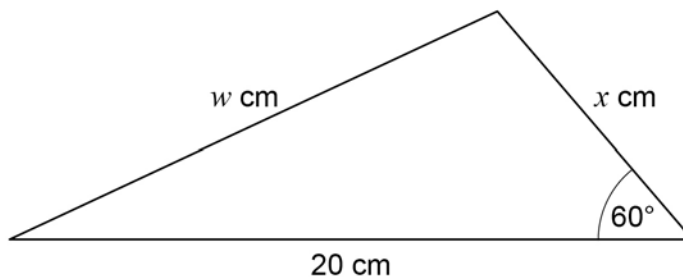

Work out the value of w .

Give your answer in the form $a\sqrt{b}$ where a and b are integers greater than 1

[5 marks]

Answer _____

27 Here is a sketch of $y = \cos x$ for values of x from 0° to 360°

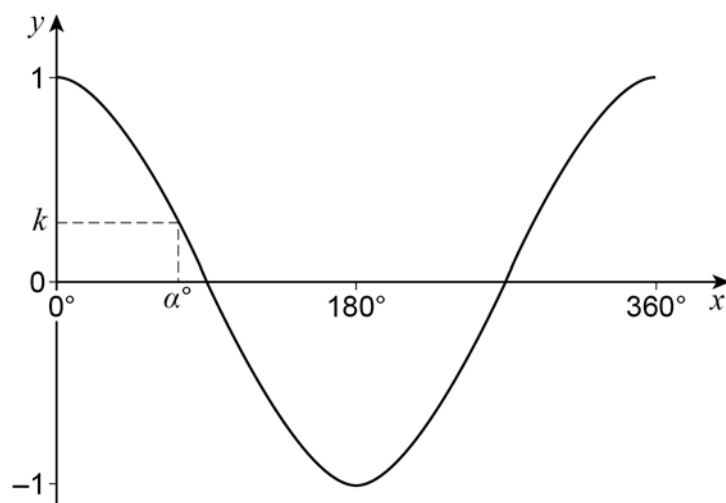

α° is an acute angle.

$$\cos \alpha^\circ = k$$

27 (a) Circle the value of $\cos (180^\circ - \alpha^\circ)$

[1 mark]

$1 - k$

k

$-k$

$-1 - k$

27 (b) Circle the value of $\cos (360^\circ + \alpha^\circ)$

[1 mark]

$k - 1$

$k + 1$

$-k$

k

END OF QUESTIONS

There are no questions printed on this page

*Do not write
outside the
box*

**DO NOT WRITE ON THIS PAGE
ANSWER IN THE SPACES PROVIDED**

Copyright information

For confidentiality purposes, from the November 2015 examination series, acknowledgements of third-party copyright material will be published in a separate booklet rather than including them on the examination paper or support materials. This booklet is published after each examination series and is available for free download from www.aqa.org.uk after the live examination series.

Permission to reproduce all copyright material has been applied for. In some cases, efforts to contact copyright-holders may have been unsuccessful and AQA will be happy to rectify any omissions of acknowledgements. If you have any queries please contact the Copyright Team, AQA, Stag Hill House, Guildford, GU2 7XJ.

Copyright © 2018 AQA and its licensors. All rights reserved.